

Corby Steel Fabrications Ltd

Introduction - Corby Steel Fabrications Ltd, based in County Leitrim, was established in 1990 and originally focused on structural steel and agricultural machinery. Since 2015, under Ronan Corby, the company has expanded into commercial fabrication, bespoke machinery, and industrial maintenance, serving sectors across Ireland and the UK.

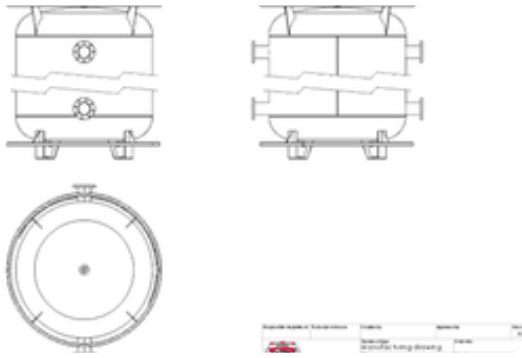

Challenge - Engagement with power and energy customers revealed inefficiencies and safety risks in existing tank systems, including slow operation, limited capacity, and vacuum hazards. While initially focused on a new transformer vacuum tank, the project shifted to developing the capability to design and manufacture advanced bespoke tanks for multiple industrial applications, requiring improved design, manufacturing, and material selection.

Solution - Through an 18-month Innovation Boost project, Corby Steel developed the ability to design and manufacture advanced bespoke tanks using 3D CAD, structural optimisation, and modern materials, creating safer, more accurate, and adaptable designs for multiple industrial applications.

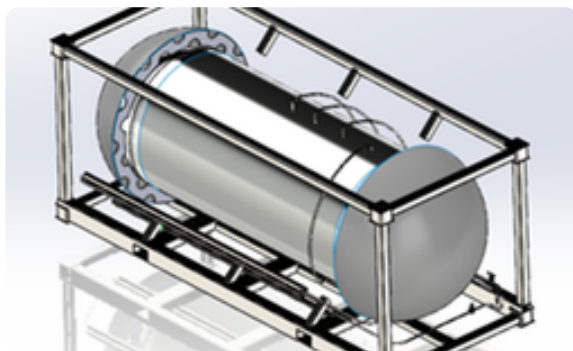
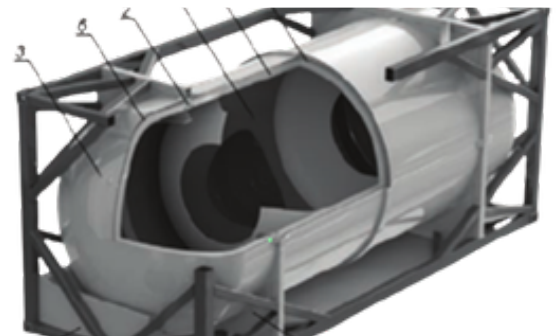

Impact - The project strengthened Corby Steel's design and manufacturing capability, enabling safer, more efficient, and adaptable bespoke tanks. Increased in-house expertise allows the company to target higher-value projects, enter new markets, and support long-term growth across Ireland and the UK.

